

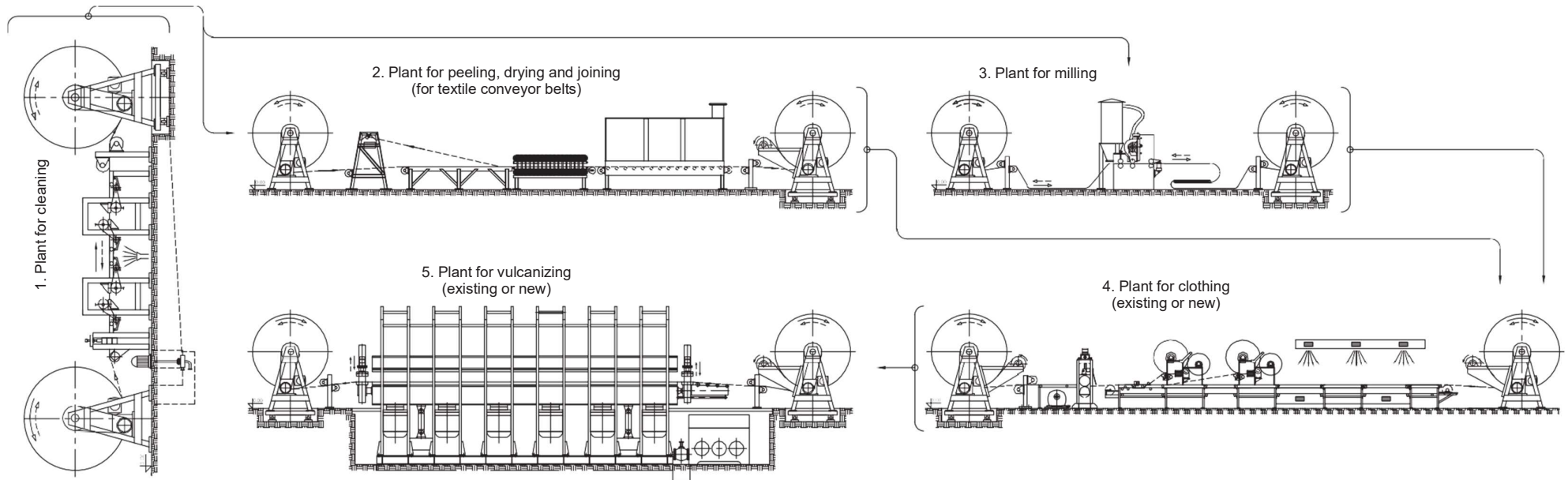

PLANTS FOR THE REGENERATION OF "RUBBER" CONVEYOR BELTS

09.23/10.4.1



Purpose:
Total regeneration of "rubber" conveyor belts.

Main technical characteristics:
Belth width (A): 1,6; 2,0; 2,4; 3,2. [m]
Other: according to your request.

We offer:
- All necessary equipment,
- (Know How)